

22" AND 24" BASS DRUMS: 10 CLAWS/HOOP

1:1 SCALE LAYOUT DRAWING



FRONT VIEW

(Place BATTER side down)

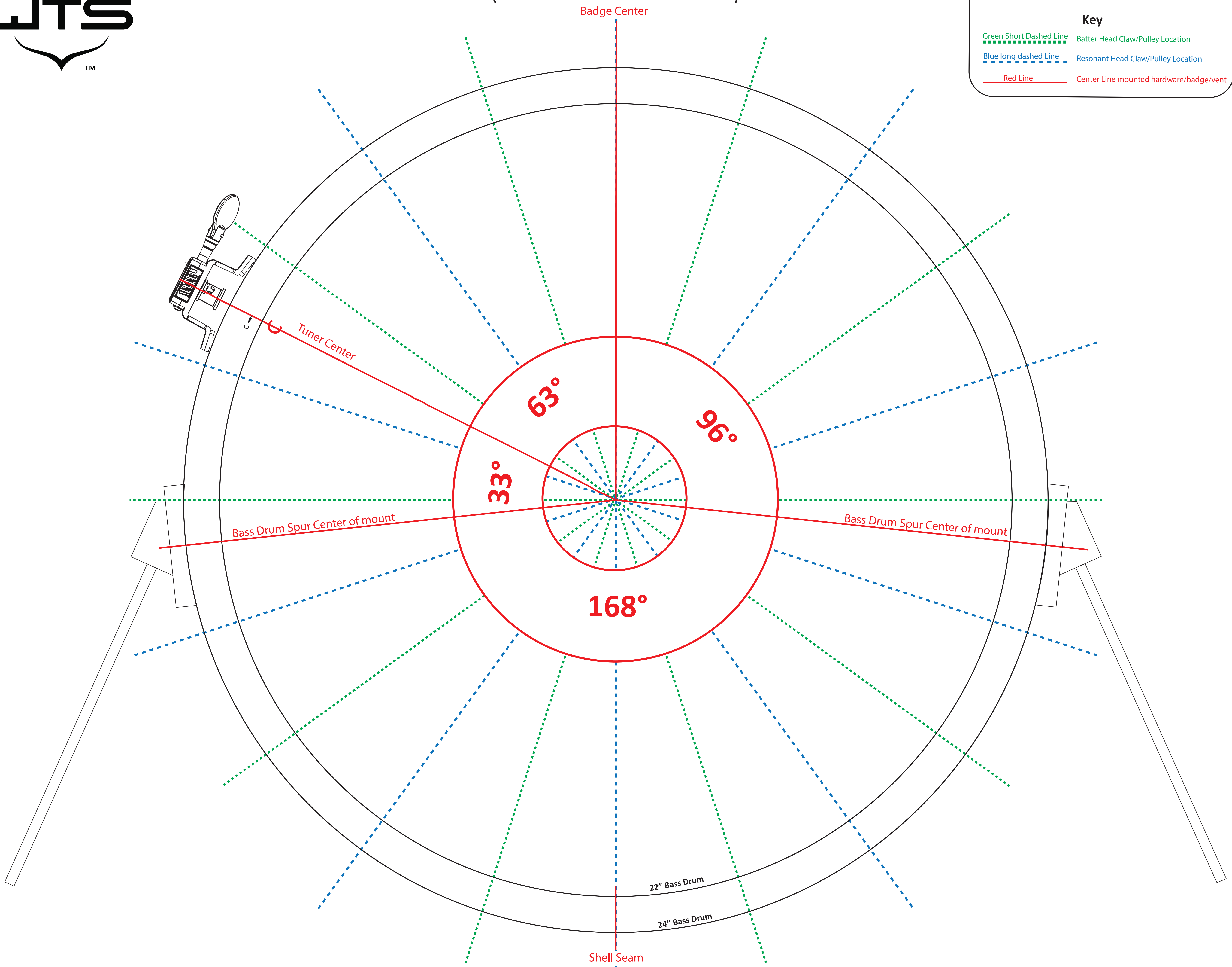

Tuning Knob: LEFT FACING

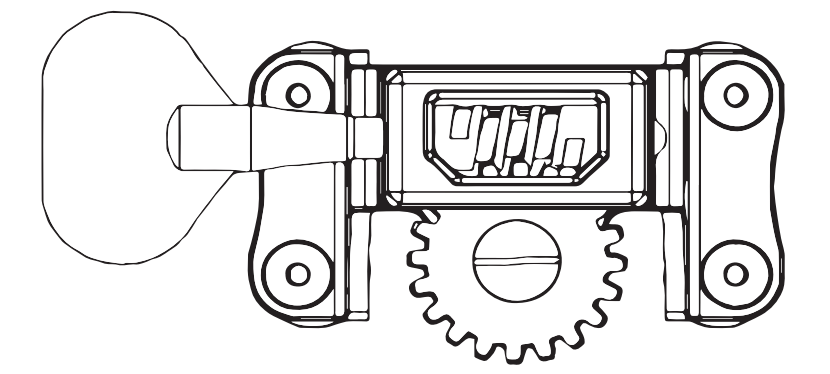

Key

- - - - - Green Short Dashed Line Batter Head Claw/Pulley Location
- - - - - Blue long dashed Line Resonant Head Claw/Pulley Location
- — — — — Red Line Center Line mounted hardware/badge/vent

Tuning Knob Drill Hole Template:

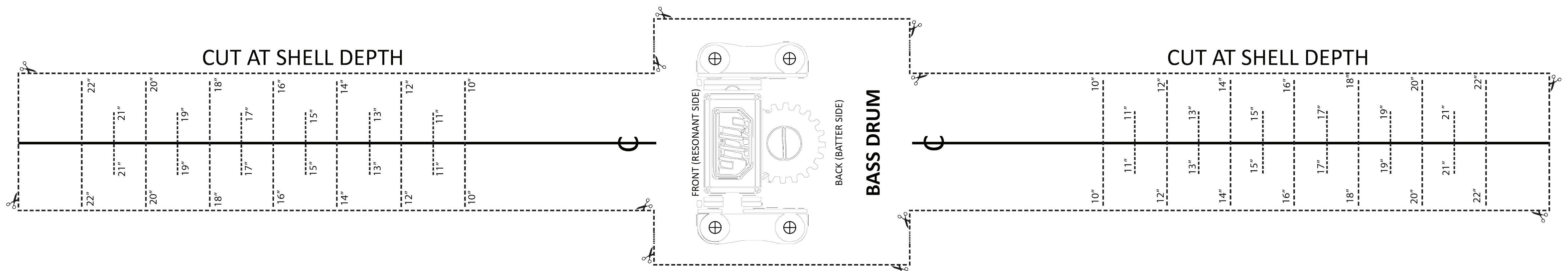

18" AND 20" BASS DRUMS: 8 CLAWS/HOOP

1:1 SCALE LAYOUT DRAWING



FRONT VIEW

(Place BATTER side down)

Tuning Knob: LEFT FACING

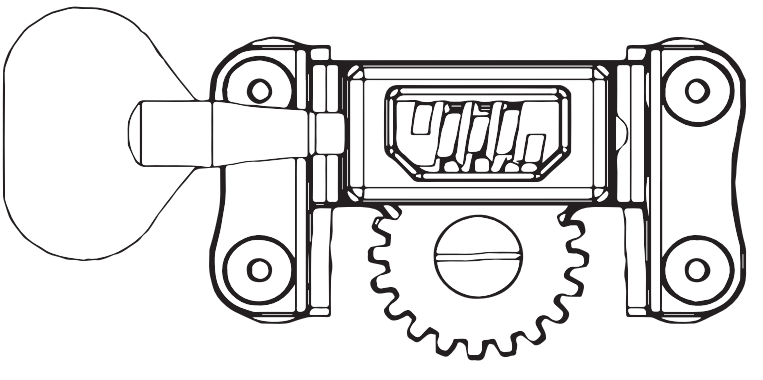

Key

- Green Short Dashed Line: Batter Head Claw/Pulley Location
- Blue long dashed Line: Resonant Head Claw/Pulley Location
- Red Line: Center Line mounted hardware/badge/vent

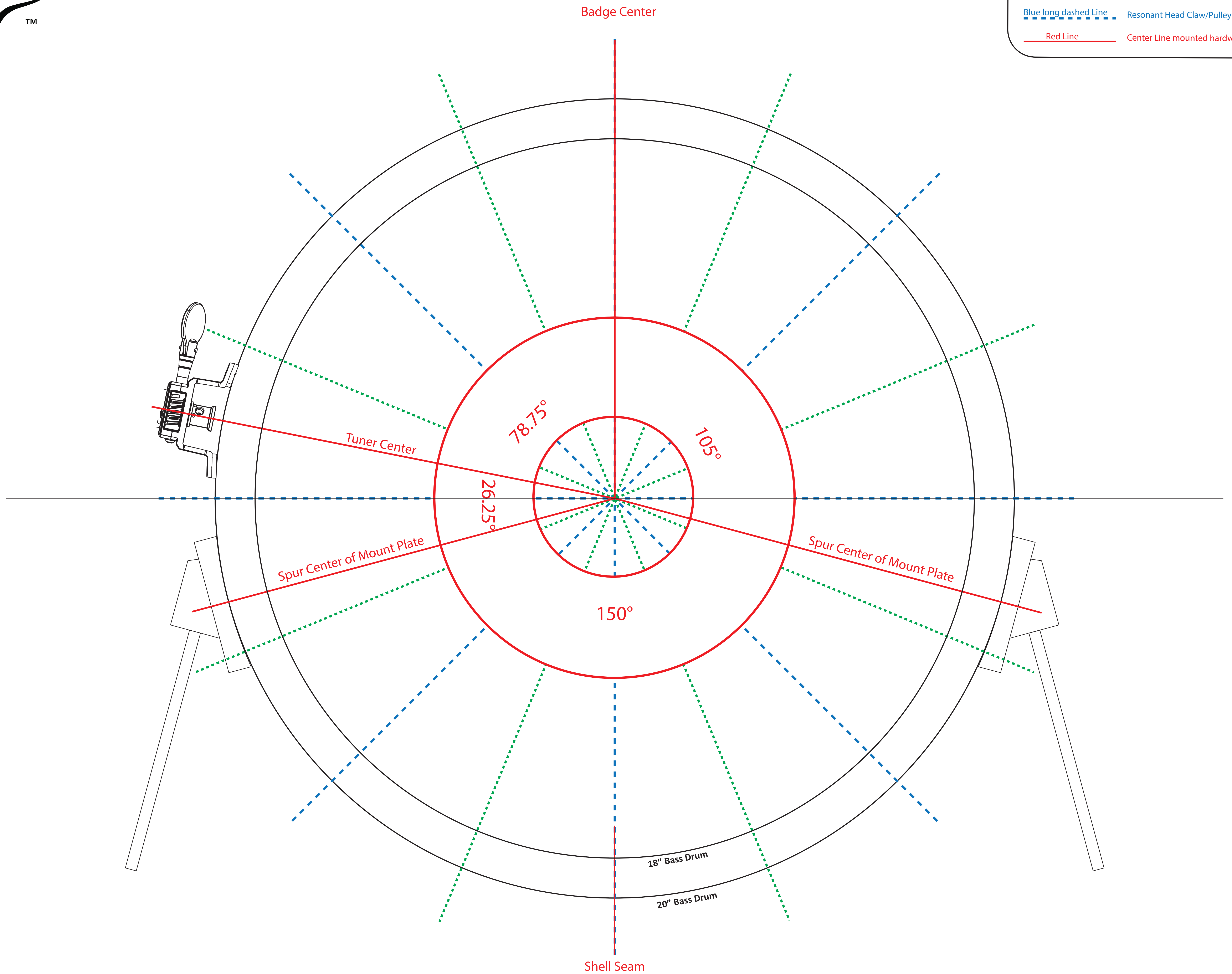

Tuning Knob Drill Hole Template:

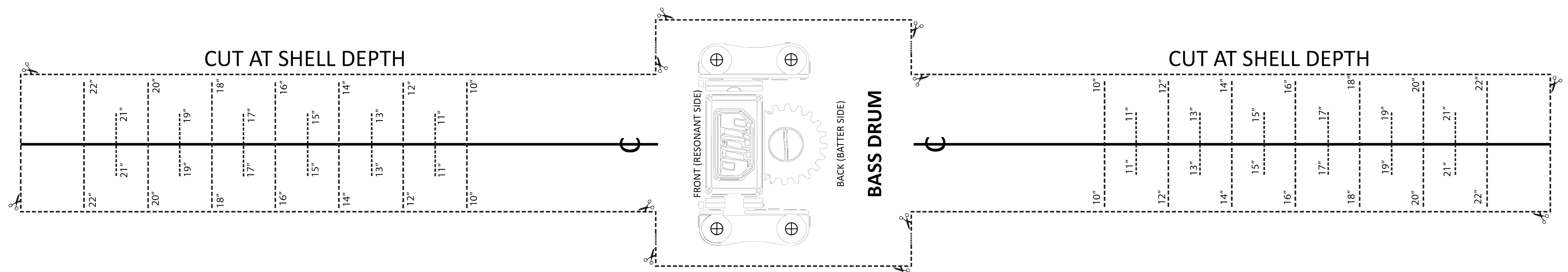

14" AND 16" FLOOR TOMS - 8 HOLE HOOPS

1:1 SCALE LAYOUT DRAWING



Tuning Knob: RIGHT FACING

Key

- Green Short Dashed Line Batter Head Claw/Pulley Location
- Blue long dashed Line Resonant Head Claw/Pulley Location
- Red Line Center Line mounted hardware/badge/vent

TOP VIEW (Place RESONANT side down)

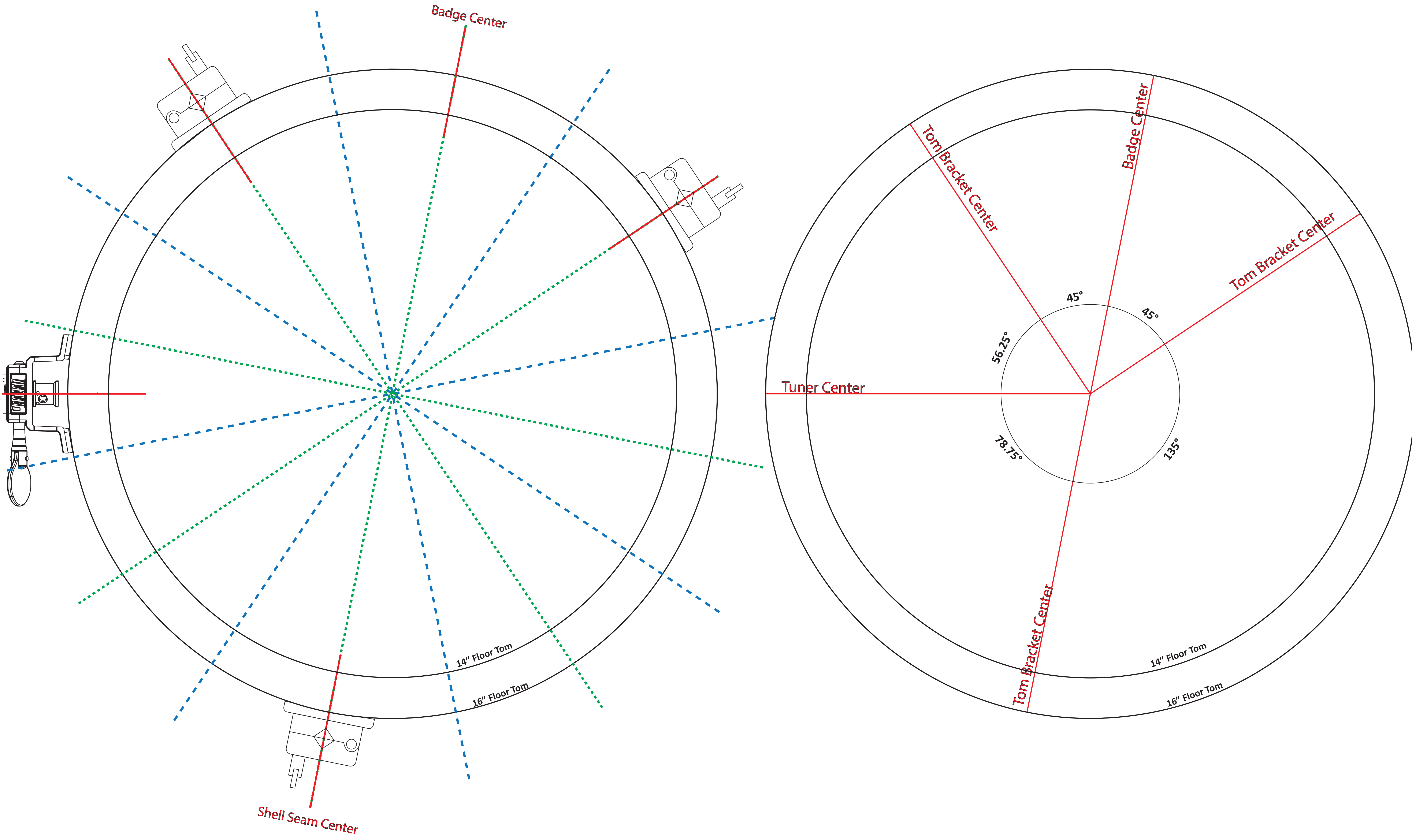

Tuning Knob Drill Hole Template:

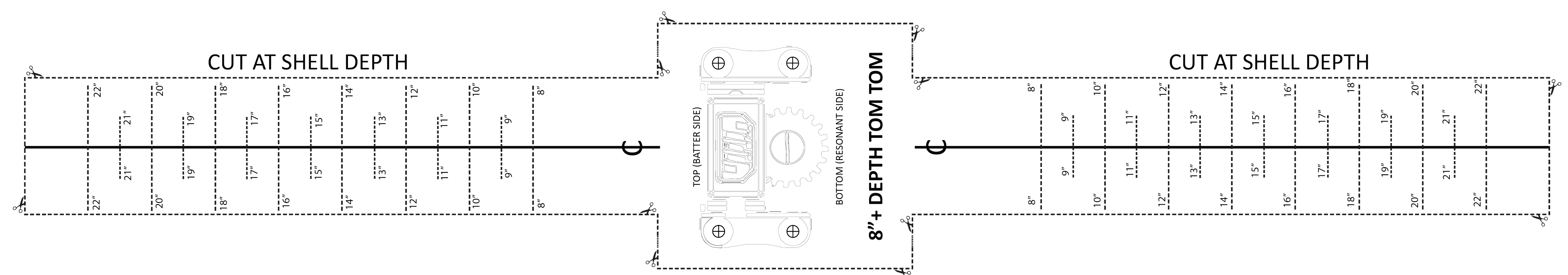

12" AND 13" RACK TOMS - 6 HOLE HOOPS

1:1 SCALE LAYOUT DRAWING



Tuning Knob: LEFT FACING

Key

- Green Short Dashed Line: Batter Head Claw/Pulley Location
- Blue long dashed Line: Resonant Head Claw/Pulley Location
- Red Line: Center Line mounted hardware/badge/vent

TOP VIEW (Place RESONANT side down)

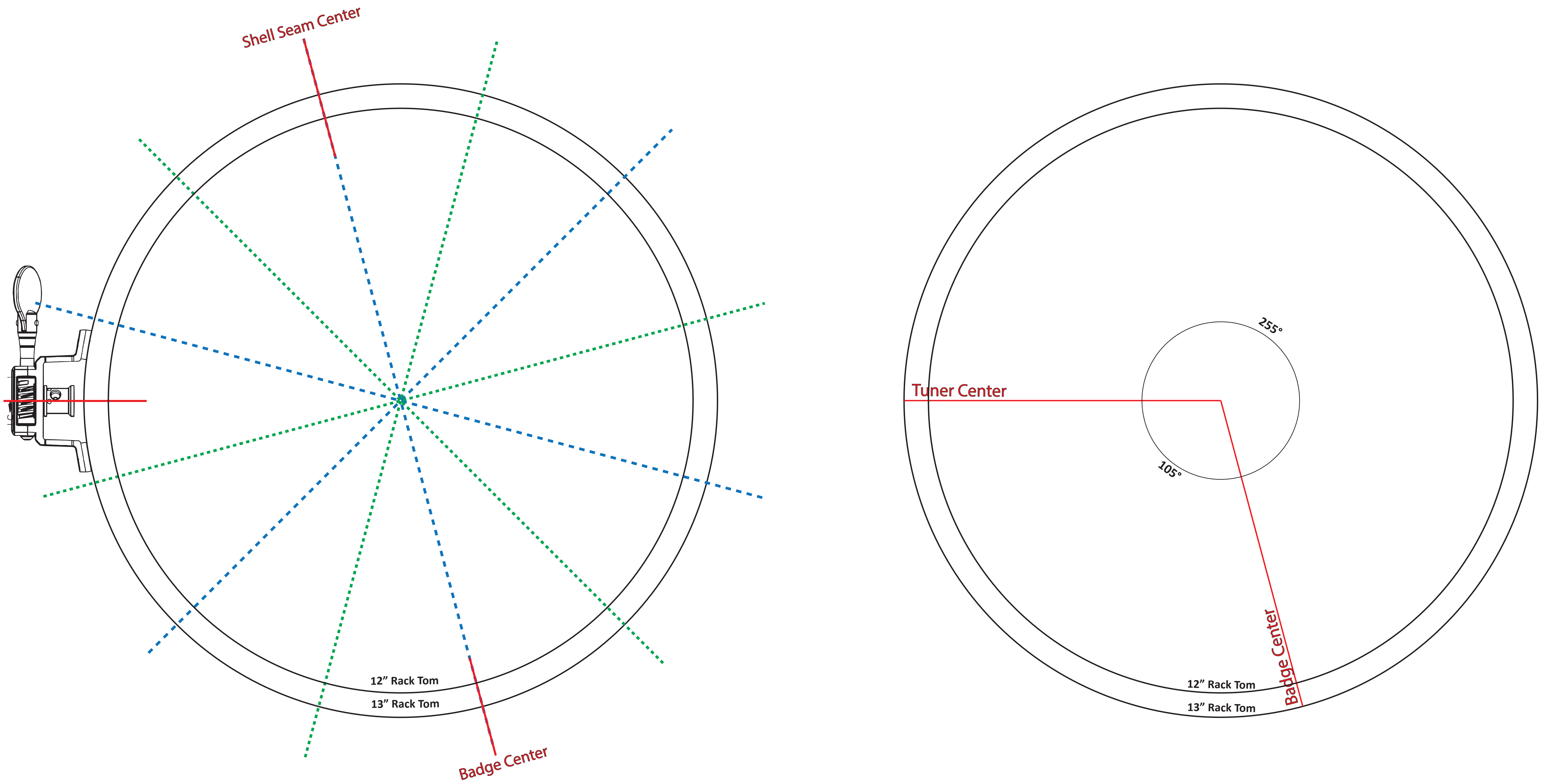

Tuning Knob Drill Hole Template:

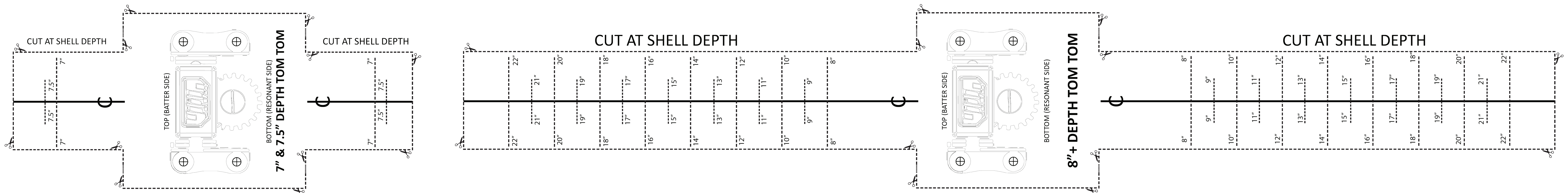

10" RACK TOMS - 6 HOLE HOOPS

1:1 SCALE LAYOUT DRAWING

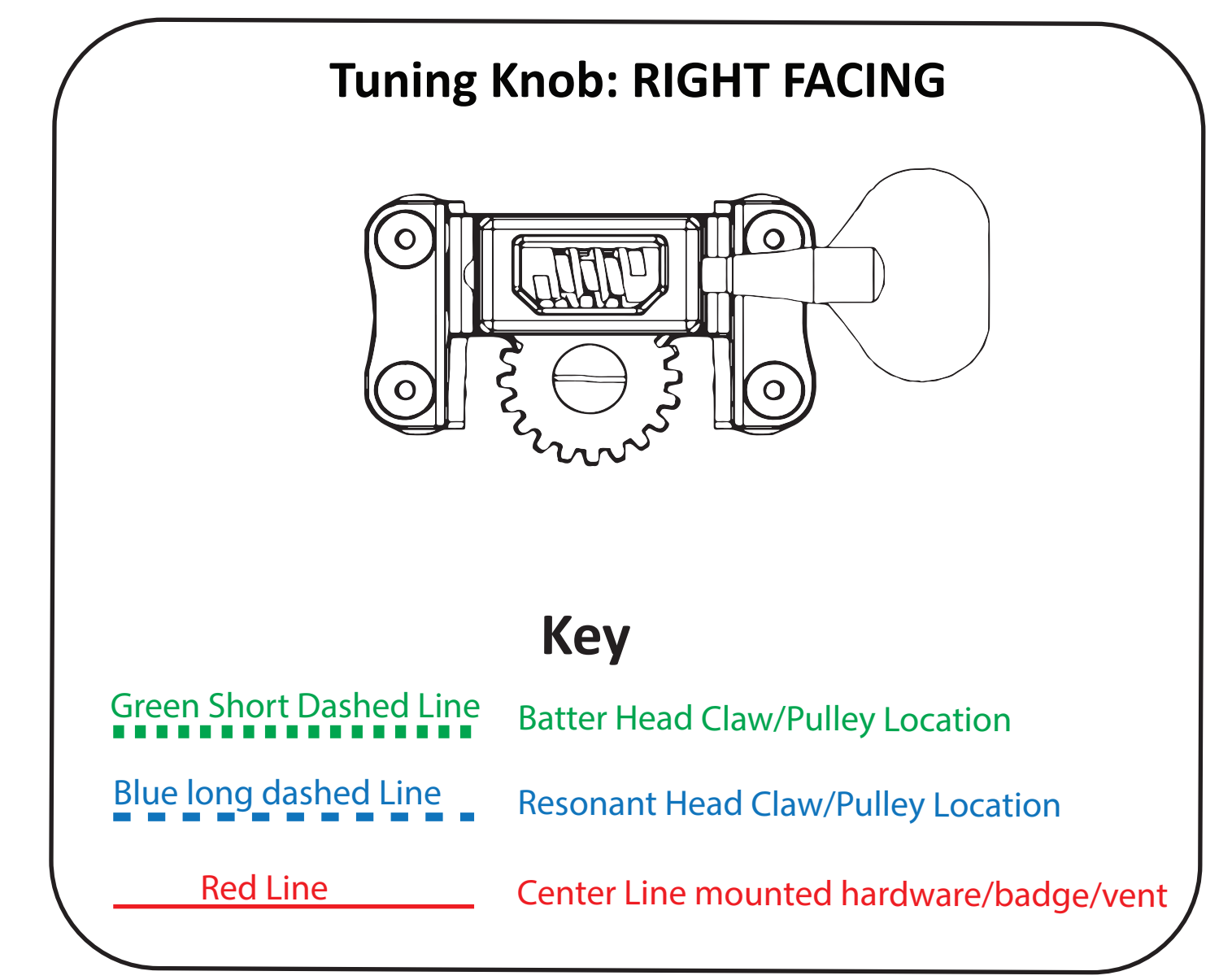

TOP VIEW (Place RESONANT side down)

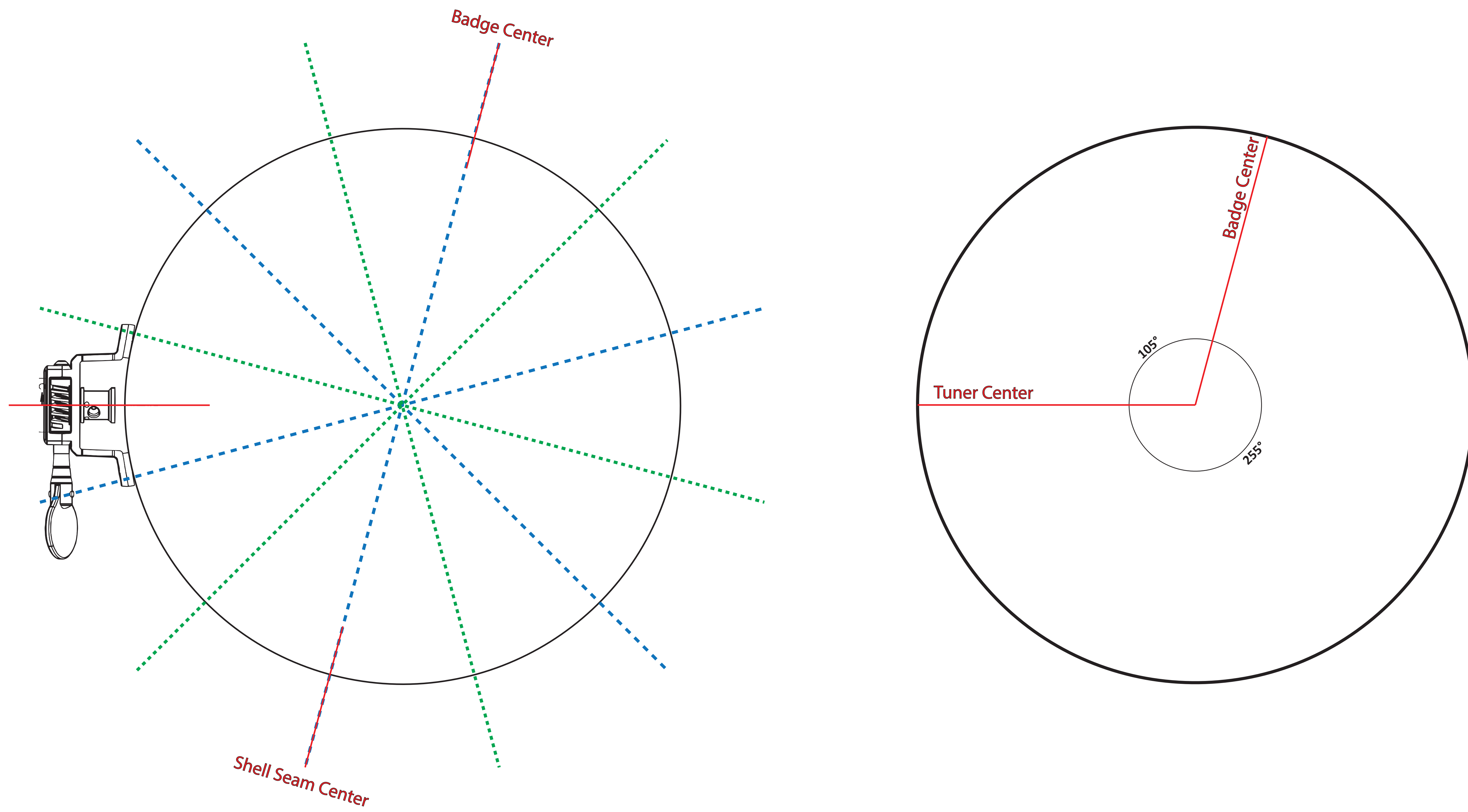

Tuning Knob Drill Hole Template:

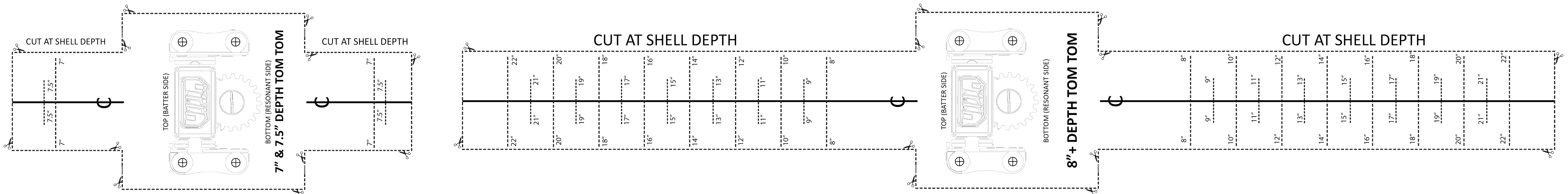

14" SNARE DRUM - 10 HOLE DIE CAST HOOPS

1:1 SCALE LAYOUT DRAWING



Tuning Knob: LEFT FACING

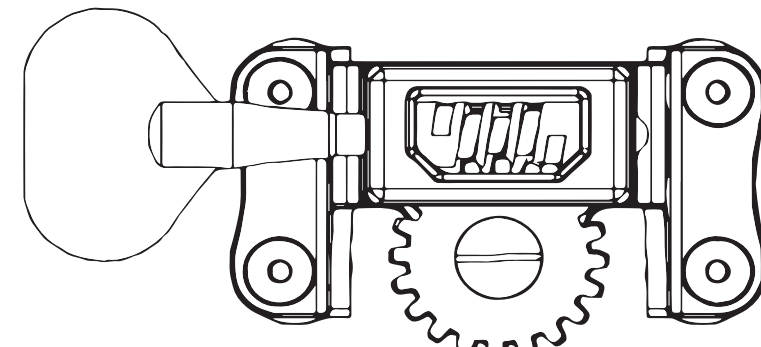

Key

- Green Short Dashed Line Batter Head Claw/Pulley Location
- Blue long dashed Line Resonant Head Claw/Pulley Location
- Red Line Center Line mounted hardware/badge/vent

TOP VIEW (Place RESONANT side down)

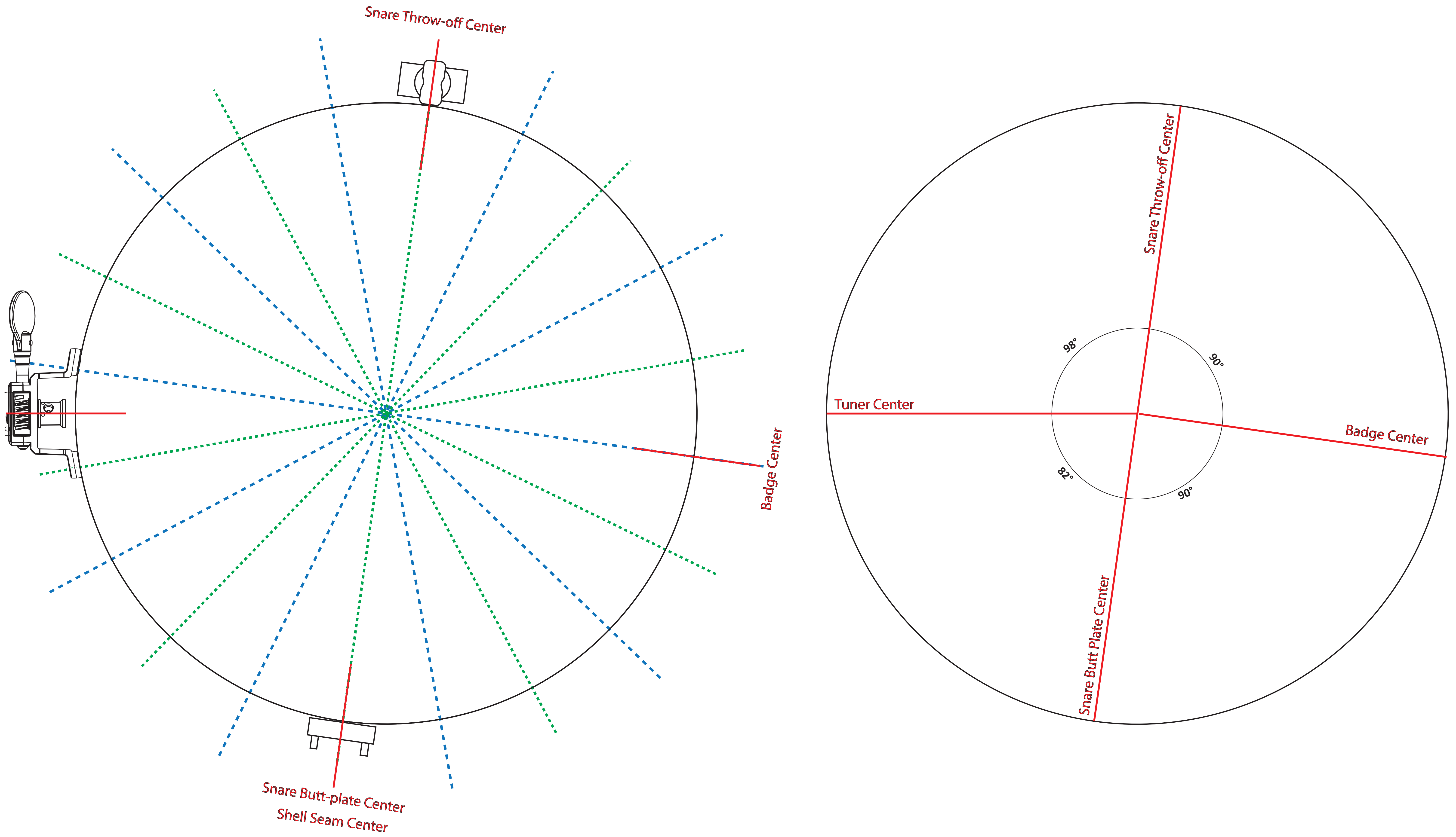

Tuning Knob Drill Hole Template:

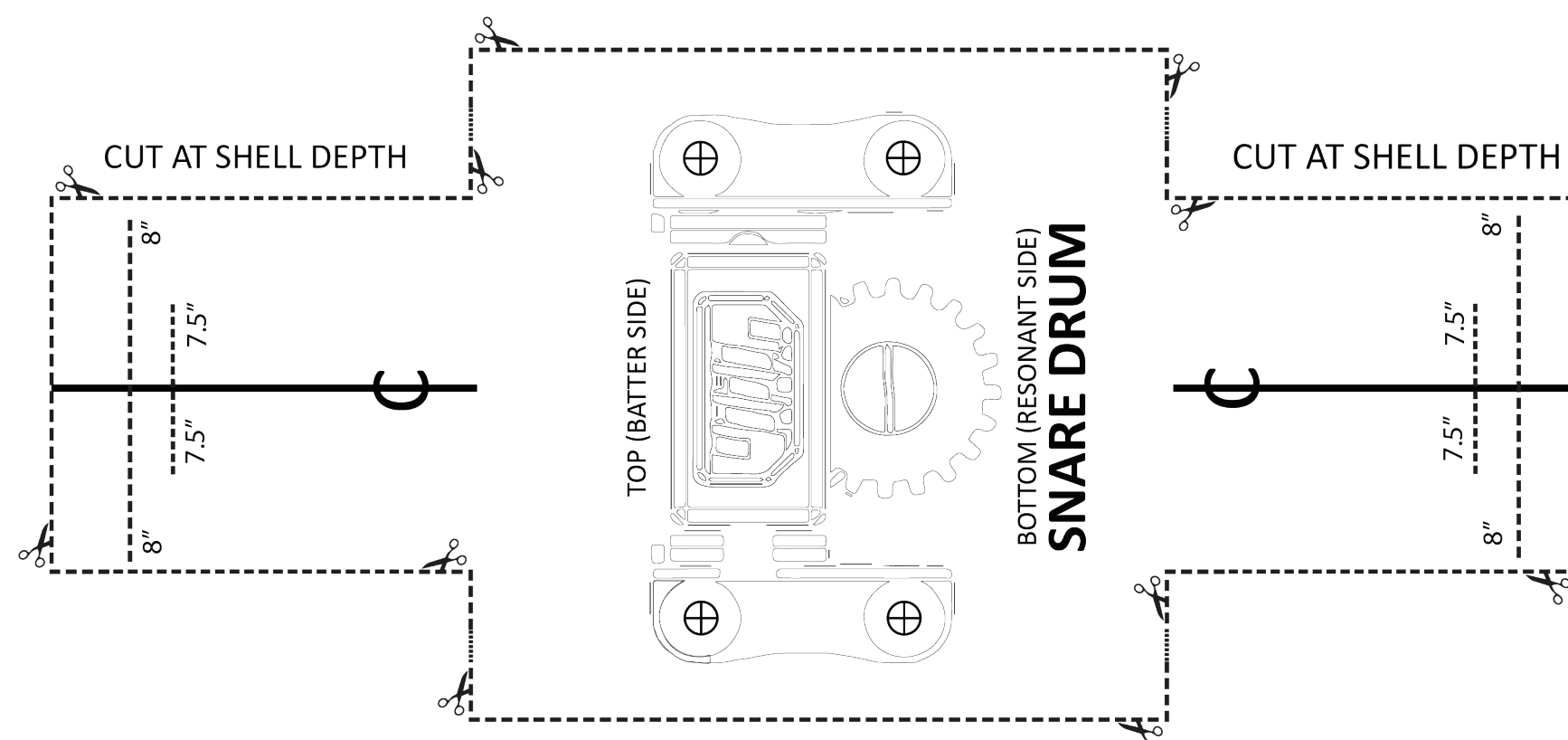

13" SNARE DRUM - 8 HOLE DIE CAST HOOPS

1:1 SCALE LAYOUT DRAWING

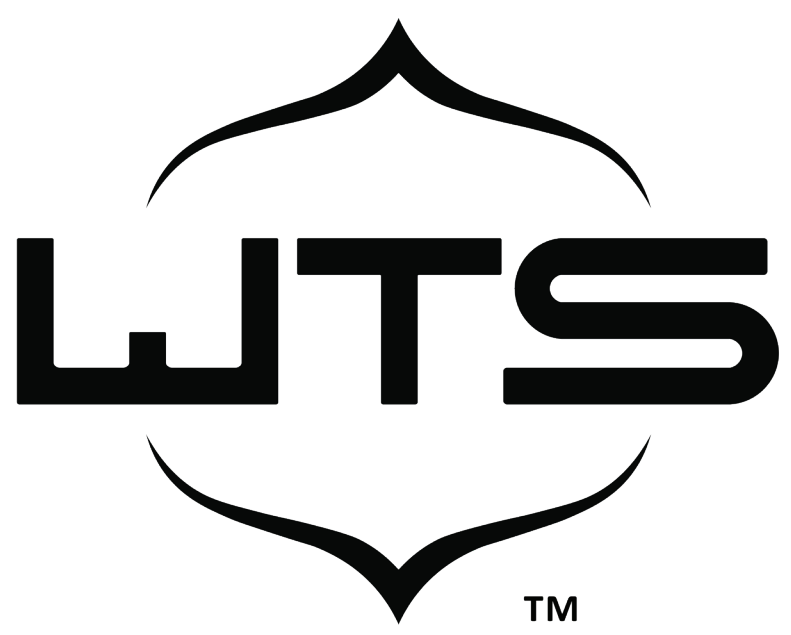

Tuning Knob: LEFT FACING

Key

- Green Short Dashed Line: Batter Head Claw/Pulley Location
- Blue long dashed Line: Resonant Head Claw/Pulley Location
- Red Line: Center Line mounted hardware/badge/vent

TOP VIEW (Place RESONANT side down)

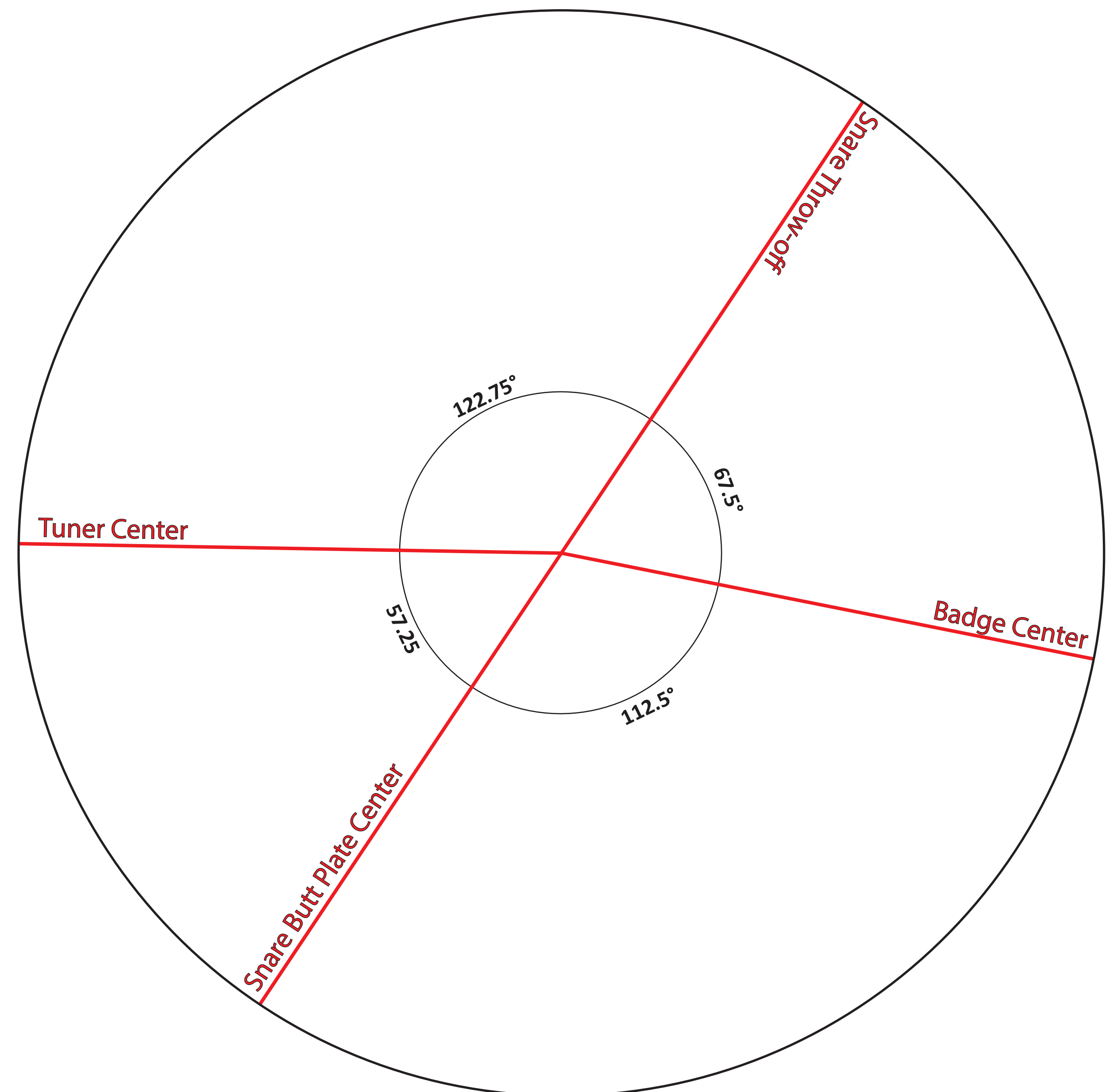
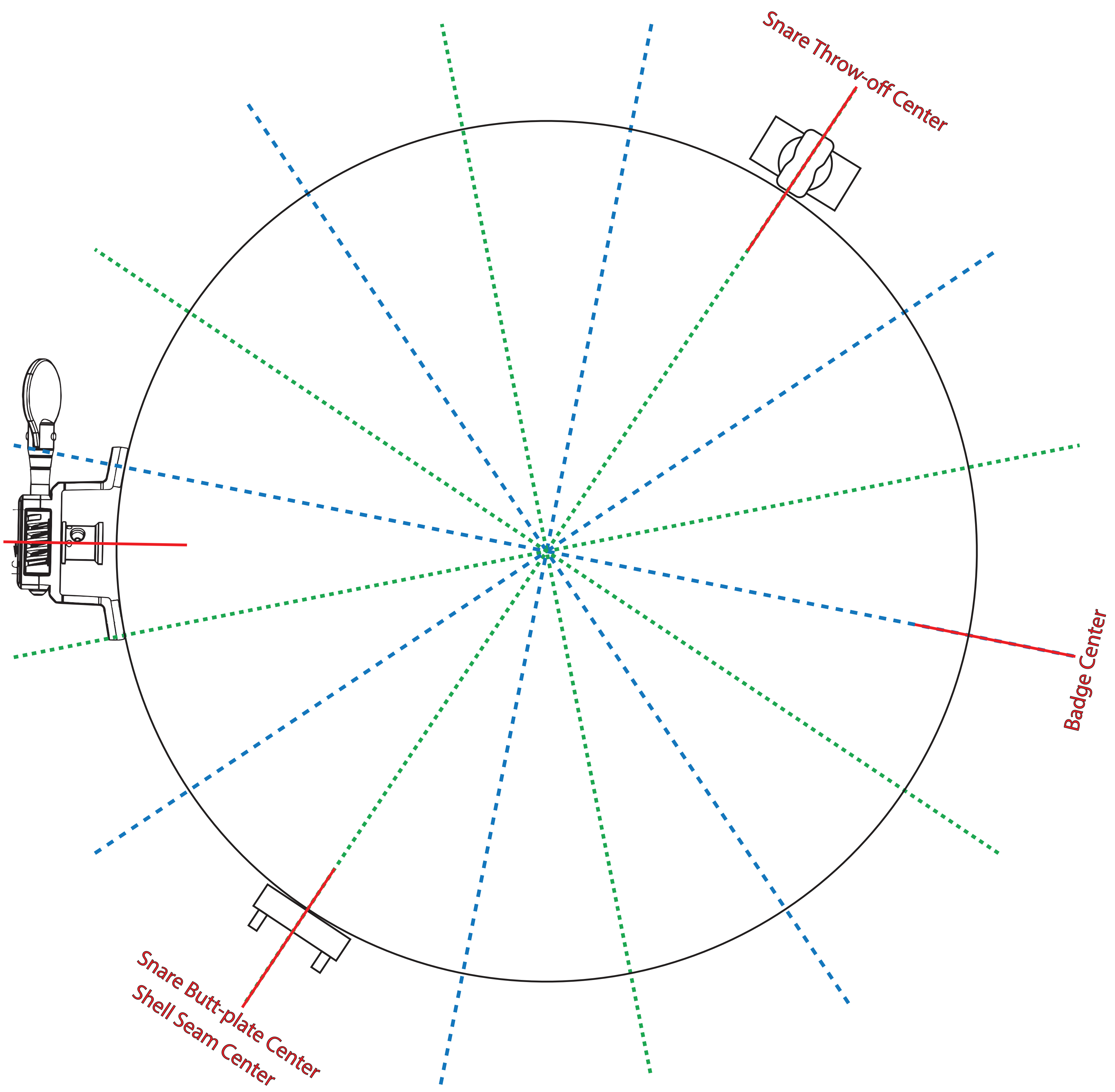

Tuning Knob Drill Hole Template:

